

THIS DRAWING IS UNPUBLISHED. RELEASED FOR PUBLICATION
 © COPYRIGHT BY TYCO ELECTRONICS CORPORATION. ALL INTERNATIONAL RIGHTS RESERVED.

LOC	DIST	REVISIONS					
BD	0	P	LTR	DESCRIPTION	DATE	DWN	APVD
		G		REVISED PER ECO-08-029128	22NOV08	HMR	MS

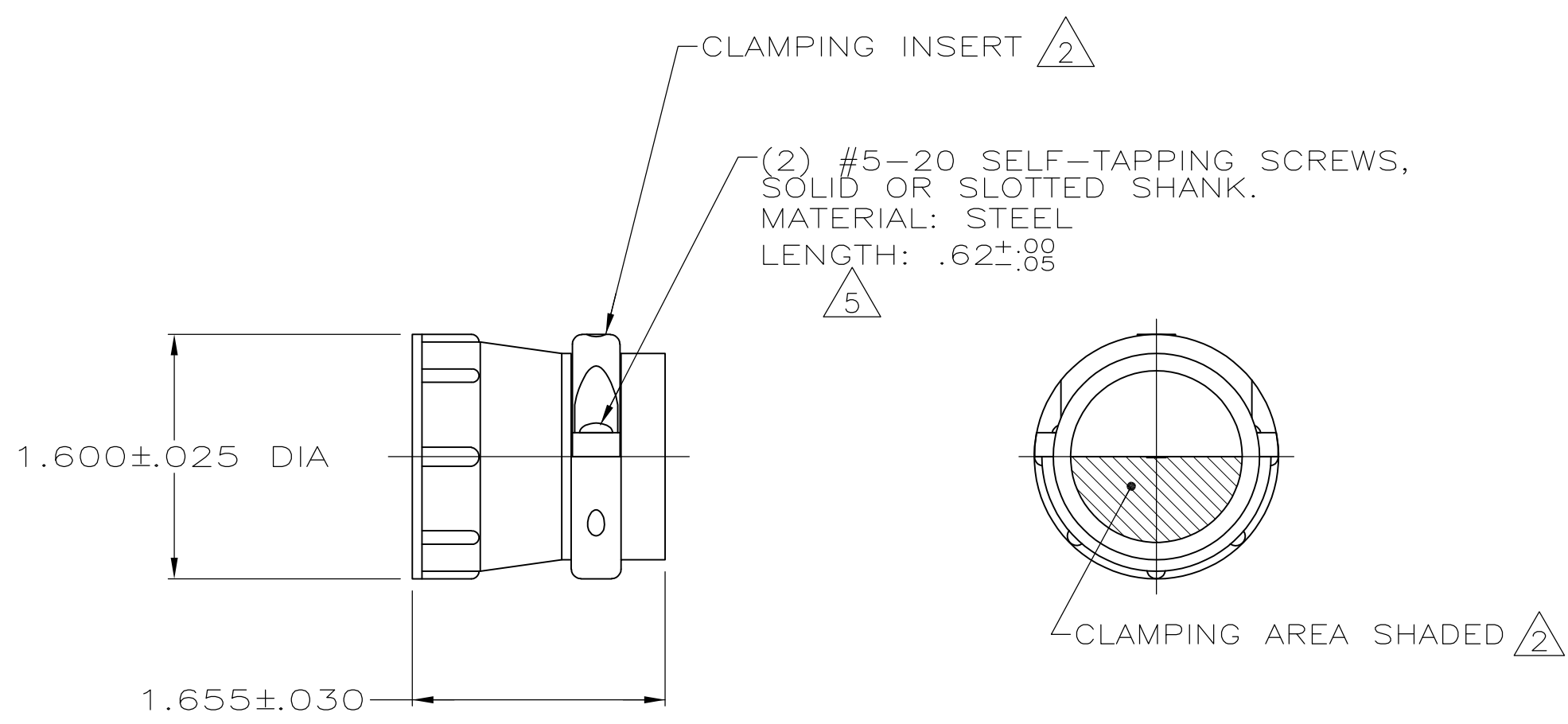

- 1 PARTS PACKAGED UNASSEMBLED.
- $\triangle 2$ CABLE CLAMPING AREA ADJUSTABLE FROM .261 TO .517 SQ IN BY CHANGING CLAMPING INSERT.
- 3 1.125 MAXIMUM CABLE OUTSIDE DIAMETER.
- $\triangle 4$ BULK PACKAGED KITS TO BE ORDERED IN MULTIPLES OF 75 ONLY.
- $\triangle 5$ FINISH: ZINC NON-HEXAVALENT CHROMATE.

$\triangle 5$	$\triangle 4$ BULK	206512-6
$\triangle 5$	INDIVIDUAL	206512-5
$\triangle 5$	SMALL PACK	206512-4
$\triangle 5$	SMALL PACK	206512-3
$\triangle 5$	$\triangle 4$ BULK	206512-2
$\triangle 5$	INDIVIDUAL	206512-1
SCREW FINISH	PACKAGING	PART NUMBER

THIS DRAWING IS A CONTROLLED DOCUMENT.		DWN A GRAFF 4/29/91	Tyco Electronics Corporation Harrisburg, PA 17105-3608																			
DIMENSIONS: INCHES		CHK W.G.LENKER 7-23-92	NAME CABLE CLAMP KIT, LARGE, SHELL SIZE 23, CPC																			
TOLERANCES UNLESS OTHERWISE SPECIFIED:		APVD -	PRODUCT SPEC 108-10024																			
<table border="0"> <tr><td>0 PLC</td><td>\pm</td><td>-</td></tr> <tr><td>1 PLC</td><td>\pm</td><td>-</td></tr> <tr><td>2 PLC</td><td>\pm</td><td>-</td></tr> <tr><td>3 PLC</td><td>\pm</td><td>-</td></tr> <tr><td>4 PLC</td><td>\pm</td><td>-</td></tr> <tr><td>ANGLES</td><td>\pm</td><td>-</td></tr> </table>		0 PLC	\pm	-	1 PLC	\pm	-	2 PLC	\pm	-	3 PLC	\pm	-	4 PLC	\pm	-	ANGLES	\pm	-	APPLICATION SPEC -	SIZE A3	CAGE CODE 00779
0 PLC	\pm	-																				
1 PLC	\pm	-																				
2 PLC	\pm	-																				
3 PLC	\pm	-																				
4 PLC	\pm	-																				
ANGLES	\pm	-																				
MATERIAL THERMOPLASTIC	FINISH -	WEIGHT -	DRAWING NO C-206512	RESTRICTED TO -																		
CUSTOMER DRAWING			SCALE 1:1	SHEET 1 OF 1																		
			REV G																			